

Instruction Manual

for

POWER  HAND[®]

90° Angle Head Assembly
Model: Z-ANX

#510-2240



Introduction

The Gesswein Power Hand Z-ANX Head Assembly is engineered and manufactured to a high degree of precision and will give you many years of trouble-free service. Backed by a limited warranty that covers wear parts for 90 days and overall balance of parts for six months.

This Head Assembly is designed to be used with the Power Hand motors in conjunction with Power Hand Single, Standard, Dual, Jewelers' Micromotor, Power Carver II, and Bright-Cutting Controllers. These controllers convert the Alternating Current (AC) power supply to a variable Direct Current (DC) by means of an I.C. "transistorized" automatically controlled circuit.

The Gesswein Power Hand 3 handpiece series consists of six models and seven head assemblies with maximum operating speeds ranging from 8,000 to 55,000rpm and 0 to 117 strokes per second. All models are identified by their names, which are engraved on the motor housings.



1. Accessories

Included Accessories

A. One $\frac{3}{32}$ " (2.35mm) Collet (reorder #501-0100)

B. One $\frac{1}{8}$ " (3.2mm) Collet (reorder #501-0105)

C. One Collet Wrench (reorder #510-0180)

Optional Accessories

A. Handpiece Extension Cord (#510-1120): adds 6 feet, or almost 2 meters, to the 1.7-meter rotary handpiece cord

B. Handpiece Cradle Rest (#510-1130): provides a safe holding place for the rotary handpiece when not in use

C. Variable-Speed Foot Rheostat (#510-3100)

D. On/Off Foot Switch (#510-3105)

E. 3mm Collet (#501-0106)

F. Reducing Collets: $\frac{1}{8}$ " to $\frac{3}{32}$ " (#816-1501), $\frac{1}{8}$ " to $\frac{1}{16}$ " (#816-1502), $\frac{3}{32}$ " to $\frac{1}{16}$ " (#816-1503), 3mm to $\frac{3}{32}$ " (#816-1504), 3mm to $\frac{1}{16}$ " (#816-1505)

2. Parts Nomenclature

1. Collet

2. Gear Housing

3. Collet Release Ring

4. Motor Connecting Ring

5. Motor Case

6. Motor Cover

7. Strain Relief

8. Electric Cord with 3-pin plug

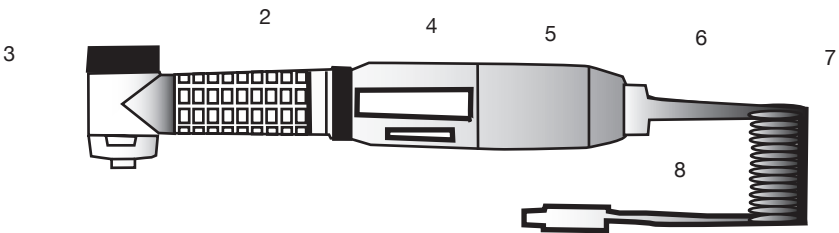
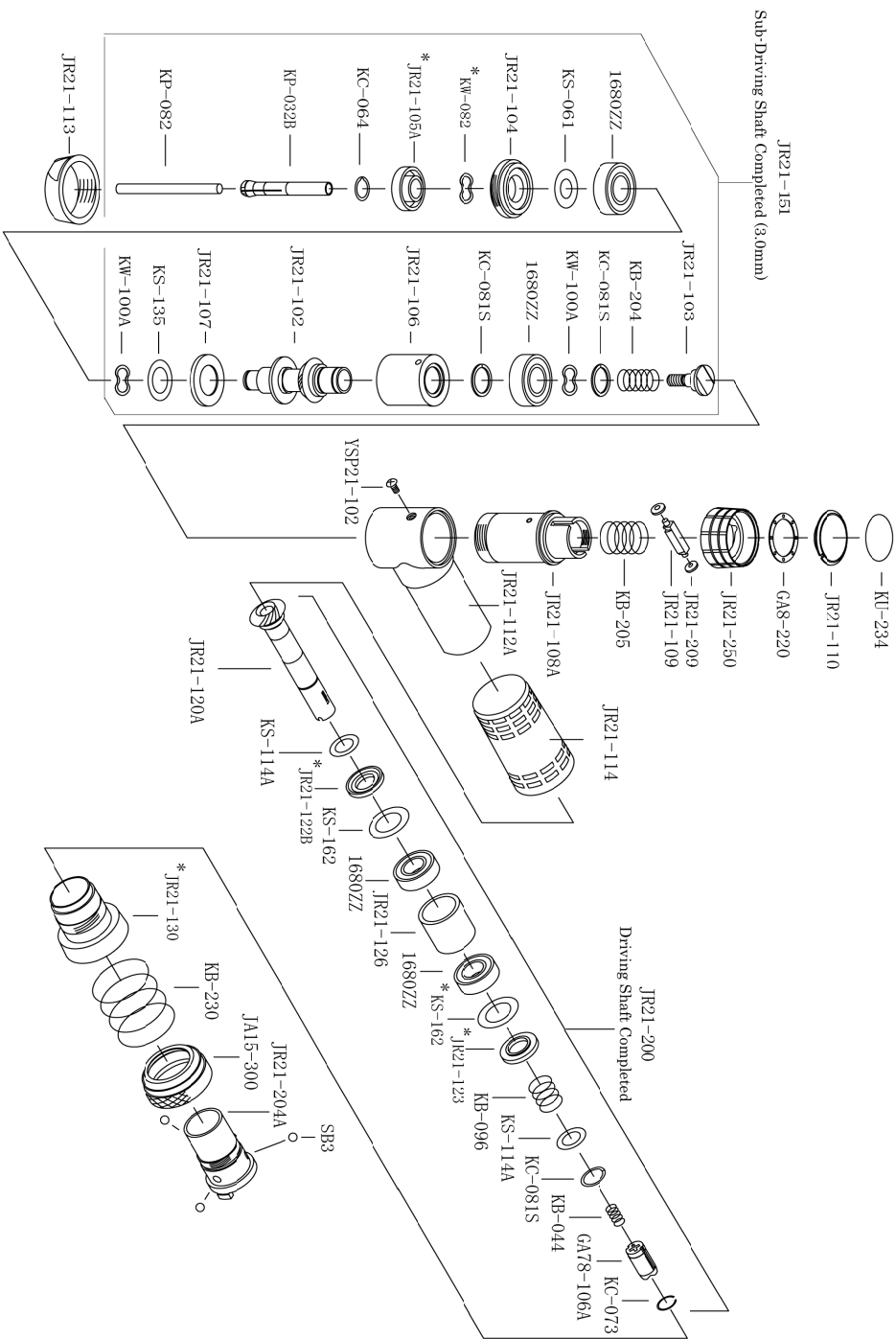

Fig. 1

Z-ANX Parts List

When ordering spare parts, always specify part# (or item# if applicable) and description.

Part#	Item#	Description
KU-234	8960265	Name Plate
JR21-110	8960266	Cap
GA8-220	8960076	Retainer
JR21-250	8960267	Set Ring
JR21-209	8960268	Roller
JR21-109	8960269	Roller Shaft
KB-205	8960270	Coil Spring
JR21-108A	8960271	Ball Bearing Case
YSP21-102	8960272	Pan Head Screw
JR21-113	8960264	Lock Nut
JR21-112A	8960273	Housing
JR21-130	8960283	Coil Spring Cover
KB-230	8960079	Coil Spring
JA15-300	8960080	Lock Ring
JR21-204A	8960284	Coupler
SB3	8960082	Stainless Steel Ball
JR21-114	8960274	Slip Protection Grip
JR21-150	8960250	Sub Drive Shaft Complete, 3/32"
JR21-151	8960251	Sub Drive Shaft Complete, 3mm
JR21-152	8960252	Sub Drive Shaft Complete, 1/8"
JR21-103	8960256	Flange Screw
KB-204	8960257	Coil Spring
KC-081S	8960258	C-Ring
KW-100A	8960259	Wave Washer
1680ZZ	5103077	Ball Bearing
JR21-106	8960260	Bearing Spacer
JR21-102	8960261	Sub Drive Shaft
JR21-107	8960262	Dust Seal A
KS-135	8960263	Spacer
KS-061	8960253	Spacer
JR21-104	8960254	Dust Collar A
JR21-105A	8960255	Dust Collar B
KC-064	8960056	C-Ring
KP-036B	5010100	Collet, 3/32" (2.35mm)
KP-032B	5010106	Collet, 3mm
KP-033B	5010105	Collet, 1/8" (3.175mm)
JR21-200	8960275	Drive Shaft Complete
JR21-120A	8960276	Drive Shaft
JR21-122B	8960277	Dust Collar
KS-162	8960279	Spacer
JR21-126	8960280	Bearing Spacer B
KB-096	8960281	Coil Spring
KS-114A	8960282	Spacer
KB-044	8960067	Coil Spring
GA78-106A	5100151	Nylon Coupler (Joint)
KC-073	8960068	C-Ring
KP-615A	5100180	CHUCK WRENCH
KW-082	8960141	WAVE WASHER
JR21-123	8960278	DUST PROOF COLLAR



3. General Description of Use

Tool Changing

The Gesswein Power Hand Angle Rotary Handpiece uses a quick-tool-release mechanism that allows for rapid tool changes. To operate, turn the Collet Release Ring counterclockwise toward the arrow pointing to the “R” or release position (see fig. 2). When in the full “R” position, the Collet Release Ring will make a click sound; the collet is then fully open and ready to accept a tool.

To secure the tool, turn the Collet Release Ring toward the “S” or secure position. Again, a click sound will be heard, indicating the collet is fully closed and the tool is secure.

When changing tools, be sure that the handpiece motor is not running. If you attempt a tool change under this condition, the motor will be stalled and damage will occur.

Collet Removal

The Angle Rotary Handpieces can accept many different size collets (see Specifications). Standard sizes are $\frac{3}{32}$ " (2.35mm) and $\frac{1}{8}$ " (3.2mm).

To change collets, turn the Collet Release Ring to the full “R” position and remove the tool in the collet. Hold the collet between the thumb and forefinger and turn in a counterclockwise direction until the collet is removed (see fig. 3). Insert the new collet and reverse the procedure. It is best to always tighten a replaced collet by hand using the Collet Wrench (#510-0180), securing until just tight.

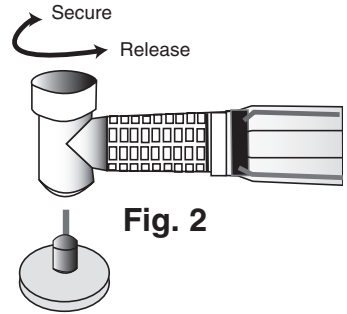

Fig. 2

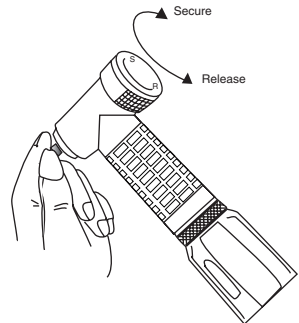

Fig. 3

If the collet cannot be loosened by hand using the Collet Wrench, additional torque may be required. To use the Collet Wrench, place the triangular cutout in the wrench over the collet and turn counterclockwise to loosen and clockwise to tighten the collet. If more torque is required, hold the handpiece with the Collet Wrench secure on the collet, and tap the wrench with a solid tool (see fig. 3a) in a counterclockwise direction. This procedure will loosen the collet, which can then be removed by hand.

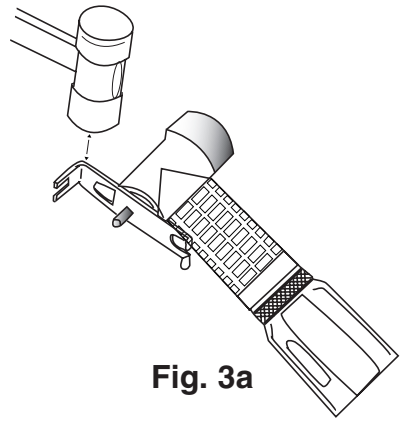

Fig. 3a

If the collet is so tight that the above procedure will not loosen it, then remove the Head Assembly from the Motor Assembly. This can be done by grasping the Motor Connecting Ring (see fig. 1) and pulling upward. Insert the Chuck Joint Wrench (see fig. 3b) into the Nylon Coupler (#510-0151), hold the Head Assembly and Wrench securely in one hand, and with the Collet Wrench in place on the collet, loosen in a counterclockwise direction (for parts drawing, refer to page 11).

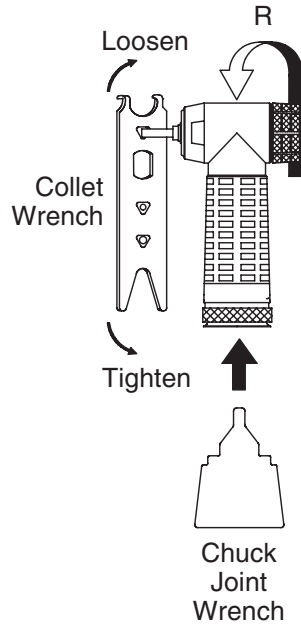

Fig. 3b

After a collet is replaced, be sure that the Collet Release Ring is rotated to its full "S" position and that the collet rotates freely when turned by hand. If the collet does not rotate freely, it is not fully seated in the Head Assembly, and you must repeat the removal-replacement procedure.



Power Hand controllers and handpieces combine to create the most versatile finishing system in the industry, offering rotary, profiling and belt sanding action.

Power Hand component selection:

- 2 controllers
- Six motors (three high torque, two standard, and one high speed)
- A selection of 8 heads
- Two reciprocating profilers
- One side-to-side profiler
- Belt Sander



201 Hancock Ave. Bridgeport, CT 06605, USA
orders 800.243.4466 | 203.366.5400 | fax 203.366.3953
email info@gesswein.com | www.gesswein.com