



E-FORCE
BELT SANDER DBT30
ITEM# 510-8018

OPERATION MANUAL

Thank you very much for purchasing **E-FORCE** Belt Sander Attachment (DBT30). Please read this operation manual carefully and understand completely about the tool before using.
 Please keep this operation manual available for future reference whenever necessary.

1. SAFETY PRECAUTIONS

- Please read OPERATION MANUAL and SAFETY PRECAUTIONS carefully before using any tools, and use tools properly.
- The instructions are provided to use tools safely, and to prevent damages to the life body and property.
 Always follow the SAFETY PRECAUTIONS in this manual.

Symbols for Securing Safety

	WARNING Incorrect use of the tools could cause fatal or serious bodily injury.
	CAUTION Incorrect use of the tools could cause serious bodily injury, or damage to property.
	Symbol to prohibit one's doings in handling the product.
	Symbol to compel one's doings in handling the product.

WARNING SAFETY PRECAUTIONS FOR MICRO GRINDERS

	<ul style="list-style-type: none"> ■ This tool is designed and made to function as a handheld grinder. Read carefully and completely this operation manual before using. <ul style="list-style-type: none"> · Ignoring this instruction may result in accident, injury, and trouble of the tool. 		<ul style="list-style-type: none"> ■ Install the tool so that installing length (overhang) becomes 13mm or less. (Fig.1) <ul style="list-style-type: none"> · If longer overhang is used, decrease the speed. (Table-1) · The tool may be damaged and result in accident and/or injury.
	<ul style="list-style-type: none"> ■ NEVER use the tool to human body. Keep children away. <ul style="list-style-type: none"> · Incorrect use of the tool may result in serious accident and/or injury. 		<ul style="list-style-type: none"> ■ Use proper power outlet to fit plug of tool, and DO NOT remodel plug. <ul style="list-style-type: none"> · Risk of electric shock is reduced by using original plug and corresponding power outlet.
	<ul style="list-style-type: none"> ■ Use safety protections. <ul style="list-style-type: none"> · Always use safety glasses when operating the tool, and use dust protection mask in dusty working condition. 		<ul style="list-style-type: none"> ■ DO NOT use the tool under excessive electric noise. <ul style="list-style-type: none"> · It may cause malfunction and trouble of the tool, which may result in accident and/or injury.
	<ul style="list-style-type: none"> ■ Wear suitable clothing. <ul style="list-style-type: none"> · Groves, hair, and clothing may be caught in rotating part, resulting in accident and/or injury. 		<ul style="list-style-type: none"> ■ NEVER use the tool in damp or wet conditions. <ul style="list-style-type: none"> · Water may enter the tool and there is risk of getting electric shock.
	<ul style="list-style-type: none"> ■ Keep work area well lit and neat. <ul style="list-style-type: none"> · Inadequately lit work area and untidy work bench may result in accident and/or injury. 		<ul style="list-style-type: none"> ■ DO NOT abuse the power cord by pulling it. <ul style="list-style-type: none"> · The cord may be damaged and there is risk of fire and electric shock.
	<ul style="list-style-type: none"> ■ DO NOT operate the tool in the presence of flammable liquids, gases, or dust. <ul style="list-style-type: none"> · Grinding sparks may cause fire or explosion. 		<ul style="list-style-type: none"> ■ DO NOT touch the power plug with wet hands. <ul style="list-style-type: none"> · There is risk of getting electric shock.
	<ul style="list-style-type: none"> ■ DO NOT use the tool at excessively high/low ambient temperature. (Use at ambient temperature of 0°C~40°C without condensation.) <ul style="list-style-type: none"> · Condensation may cause short circuit and so on and there is risk of fire. 		<ul style="list-style-type: none"> ■ DO NOT use air blow tools to clean the tool. <ul style="list-style-type: none"> · Use brush or cloth to remove dust and stain. Using air blow tools may cause dirt entering bearing and other rotating parts, which may result in trouble of the tool.
	<ul style="list-style-type: none"> ■ Keep bystanders away whilst operating the tool. <ul style="list-style-type: none"> · It may result in unexpected accidents and/or injury when people other than the operator touch the motor cord or the power cord. 		<ul style="list-style-type: none"> ■ Carry out trial run of the tool. <ul style="list-style-type: none"> · Using the tool without trial run may result in unexpected accident and/or injury. At the beginning of work of the day : 1 minute or more. When the tool is exchanged : 3 minutes or more. After long absence of use : 5 minutes or more.
	<ul style="list-style-type: none"> ■ Keep hands, face and so on away from rotating tool. <ul style="list-style-type: none"> · Fingers or hand may be caught, or scattered objects may result in accident and/or injury. 		<ul style="list-style-type: none"> ■ Carry out dairy maintenance. <ul style="list-style-type: none"> · Inadequate maintenance and checking of the tool may result in accident and/or injury. Inspect cord and parts for any damages. Inspect the tool and holder for any damage or wear. Always maintain the grip dry and check for oil/grease or water on it.
	<ul style="list-style-type: none"> ■ DO NOT force the tool. <ul style="list-style-type: none"> · Excessive pressure may cause abnormal wear or damage of the tool, and result in accident and/or injury. 		<ul style="list-style-type: none"> ■ DO NOT lubricate bearings. <ul style="list-style-type: none"> · Excessive grease may cause increased heat and vibration, which may result in accident and/or injury.
	<ul style="list-style-type: none"> ■ DO NOT use water or grinding liquid, and DO NOT operate the tool by wet hand. <ul style="list-style-type: none"> · There is a risk of getting electric shock. The tool is designed to use in dry condition. 		<ul style="list-style-type: none"> ■ DO NOT remodel or disassemble the tool. <ul style="list-style-type: none"> · It seriously effects the safety and performance of the tool, which may result in fire, electric shock, trouble of the tool, accident and/or injury.
	<ul style="list-style-type: none"> ■ Keep holding the tool until the tool stops rotating completely. <ul style="list-style-type: none"> · The machinery itself rotates, which may result in accident and/or injury. 		<ul style="list-style-type: none"> ■ For repairs, always ask dealers or Eiko Electric Co., Ltd. <ul style="list-style-type: none"> · Repairs must be carried out by qualified person with knowledge and skills, otherwise not only the tools do not perform sufficiently, but also it may result in accident, injury, and trouble of the tool.
	<ul style="list-style-type: none"> ■ Secure the workpiece well. <ul style="list-style-type: none"> · Loose workpiece may force excessive load to the tool that may damage the tool, resulting in accident and/or injury. 		<ul style="list-style-type: none"> ■ Immediately stop operating and turn off the tool, whenever unusual noise, heat, smoke, or smell from the tool is noticed. <ul style="list-style-type: none"> · Using the tool in such condition may result in accident and/or injury such as smoke, flame and electric shock.
	<ul style="list-style-type: none"> ■ DO NOT clamp the machinery with vice and so on. <ul style="list-style-type: none"> · There is a risk of accident and/or injury when the tool is damaged. 		
	<ul style="list-style-type: none"> ■ Keep the motor cord away from the tool when in use. <ul style="list-style-type: none"> · The cord may be caught in the tool, which may result in accident and/or injury. 		
	<ul style="list-style-type: none"> ■ Confirm that spanners and wrenches are detached from the tool before using. <ul style="list-style-type: none"> · Spanners or wrenches will be blown away when the tool is turned on, which may result in accident and/or injury. 		
	<ul style="list-style-type: none"> ■ Only use the tools listed on the catalogue of Eiko Electric Co., Ltd. <ul style="list-style-type: none"> · Do not use the tools which are not listed on our catalogue. It may result in accident and/or injury. 		
	<ul style="list-style-type: none"> ■ Use the tool below the rotating speed specified by manufacturer. <ul style="list-style-type: none"> · The tool may be damaged and result in accident and/or injury. 		
	<ul style="list-style-type: none"> ■ Select proper tools for your work. <ul style="list-style-type: none"> · Selecting proper tools will achieve smooth operation and increase efficiency of work. 		
	<ul style="list-style-type: none"> ■ DO NOT use damaged tools. <ul style="list-style-type: none"> · Using tools with cracks, splits, bent shank and so on may cause breakage of tool and result in accident and/or injury. 		
	<ul style="list-style-type: none"> ■ Use tool of which diameter of shaft is within tolerance of 0 to -0.01mm against nominal diameter of collet chuck. <ul style="list-style-type: none"> · Lack of gripping force may cause unintended detachment of the tool and result in accident and/or injury. 		
	<ul style="list-style-type: none"> ■ Use mounted points of φ15mm or less when operating at maximum allowable speed. <ul style="list-style-type: none"> · The tool may be damaged and result in accident and/or injury. 		

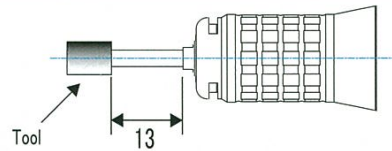

Fig.1 About Overhang

Table-1. Relation of overhang and speed.

Overhang (mm)	Maximum Allowable Speed (min ⁻¹)
20	N x 0.5
25	N x 0.3
50	N x 0.1

「N」 is Maximum Allowable Speed at 13mm overhang.

2. Product Specifications

2.1 Specifications

Product Name	Belt Sander Attachment
Model Code	DBT30
Max. Speed	20,000min ⁻¹
Applicable Motors	DMT20
Weight	227g
Belt Size	Length 300mm Width 4·6·8mm
Vibration	2.5m/s ² or less
Noise	70db or less

2.2 Standard Accessories

·Operation Manual DAMR534 x1	·Abrasive Belts 8mm #120 x2
·Wrench 1.5mm DWR15 x1	·Abrasive Belts 8mm #240 x2
·Wrench 2.5mm DWR20 x1	·Abrasive Belts 8mm #400 x2
·Abrasive Belts 4mm #120 x2	·Abrasive Belts 4mm #240 x2
·Abrasive Belts 4mm #400 x2	·Abrasive Belts 6mm #120 x2
·Abrasive Belts 6mm #240 x2	·Abrasive Belts 6mm #400 x2

2.3 Dimensions

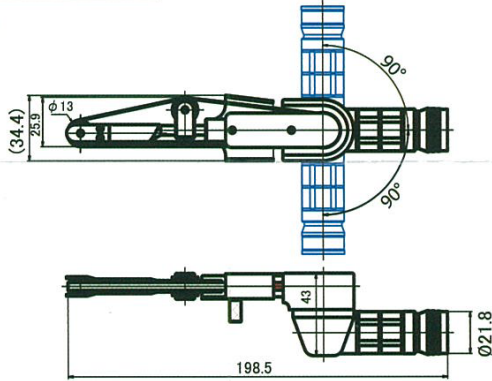

3. Description

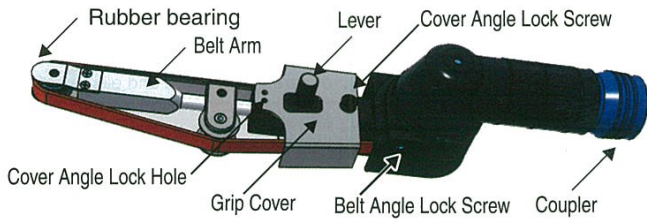

4. Connecting to Motor

CAUTION	■ Clean the connecting part when connecting to motor. Dirt entering inside may result in trouble of the tool.	!
----------------	---	---

①Connecting
Insert attachment so that index matches one of six grooves of motor.
DO NOT force attachment when cross-shape joint does not fit well. Rotate the attachment and try other grooves.

②Disconnecting
Attachment can be disconnected by thrusting Coupler to arrow direction.
※Caution that attachment may pop up by spring force.

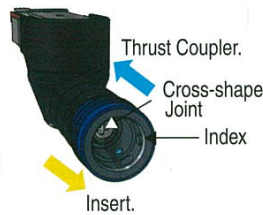

5. Replacing and Changing Angle of Belt

WARNING	■ Make sure to turn off the power before installing/removing tool. It may result in accident and/or injury.	!
CAUTION	■ Confirm that cutting chips or any other foreign substances are removed when replacing tool. It may cause deflection of shaft and result in unexpected accident and/or injury.	!

5.1 Replacing Belt.

- ①Slide lever to arrow direction.
- ②Hold the lever and replace belt.
- ③Return the lever.

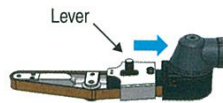

5.2 Changing Belt Angle.

- ①Loosen Belt Angle Locking Screw.
- ②Set belt angle.
- ③Tighten Belt Angle Locking Screw.

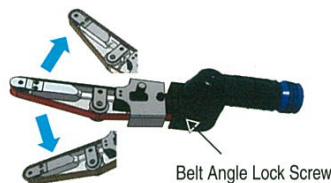

5.3 Changing Belt Direction.

- ①Slide lever to arrow direction.
- ②Hold the lever and remove belt.
- ③Turn the lever anti-clockwise and remove.
- ④Turn Belt Arm 180 degrees.
- ⑤Press and hold the Belt Arm, and install the lever by turning clockwise.
- ⑥Loosen Cover Angle Locking Screw.
- ⑦Slide grip cover to align with the pin of main body.
- ⑧Tighten the Cover Angle Locking Screw clockwise.
- ⑨Slide lever to arrow direction.
- ⑩Hold the lever and install belt.

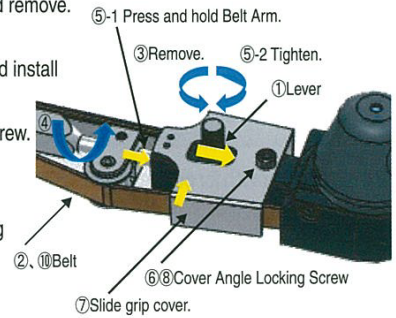

6. Operation

WARNING	■ Turn on only when the tool is not touching workpiece. Kick-back, sudden forceful reaction or breakage of tool may result in trouble of the tool and/or injury.	!
WARNING	■ Keep holding the tool until the tool stops rotating completely. The machinery itself rotates, which may result in accident and/or injury.	!

7. Trouble Shooting

When trouble is found,,

Trouble	Possible Cause	Solution
The tool does not rotate.	Breakage of bearing.	Replace bearing.
	Trouble of motor.	Repair/replace motor.
	Motor Controller is disconnected.	Connect properly.
Abnormal vibration, noise, or heat whilst rotation.	Breakage of bearing.	Replace bearing.
	Breakage of gears.	Replace gears.
Belt falls out, or slips.	Rubber bearing is worn.	Replace rubber bearing.
	O-ring is worn.	Replace O-ring.

8. Maintenance and Checking

WARNING	■ Turn off the power before maintenance and checking. It may result in accident and/or injury.	!
----------------	--	---

《Maintenance》
Remove dirt and stain with brush or cloth.

9. Optional tools

Product Name	Code No.	Model Number
Rubber Bearing	1198	DADZ386
Belt Arm (4mm)	9121100	DAAZ249
Rubber Bearing (4mm)	1199	DADZ387

MEMO

※Dispose product in accordance to local regulations.
※Specification is subject to change without notice due to continual improvements.

Gesswein www.gesswein.com

201 Hancock Ave. Bridgeport, CT 06605, USA | 800.243.4466
203.366.5400 | fax 203.366.3953 | email info@gesswein.com
MADE IN JAPAN