

GROBET USA®

**PREMIER
JEWELER'S BENCH**
NO: 13.074

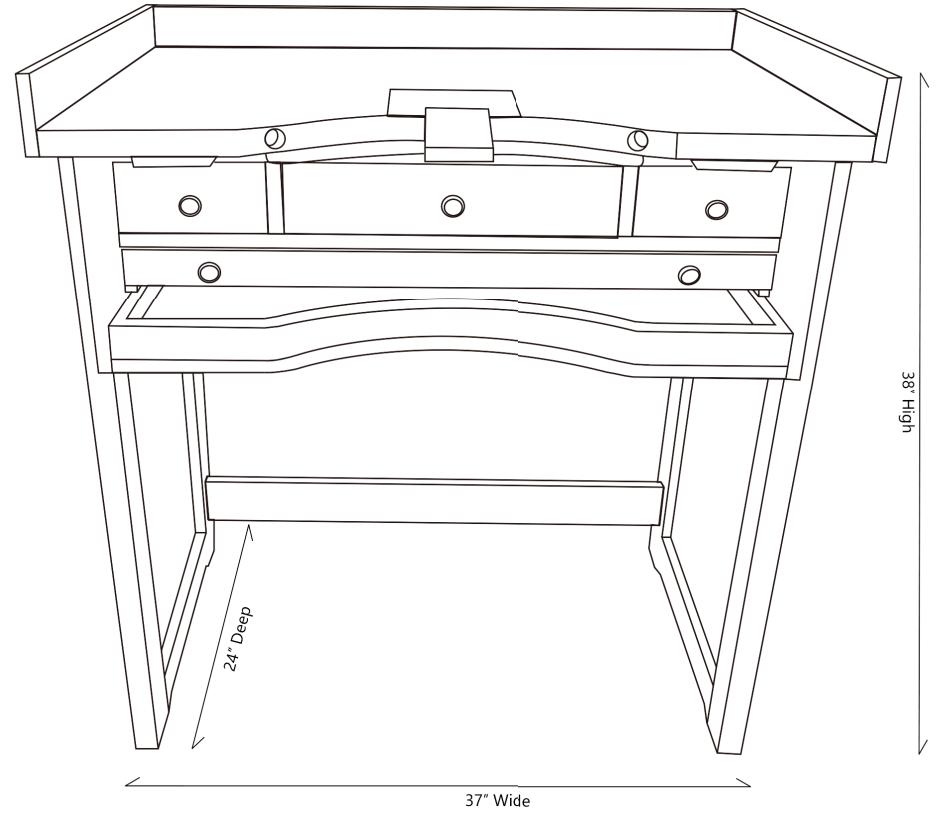

4



© COPYRIGHT 2025 Grobet File Company of America, Inc.
750 Washington Avenue • Carlstadt, New Jersey 07072
PHONE: 201-939-6700

3

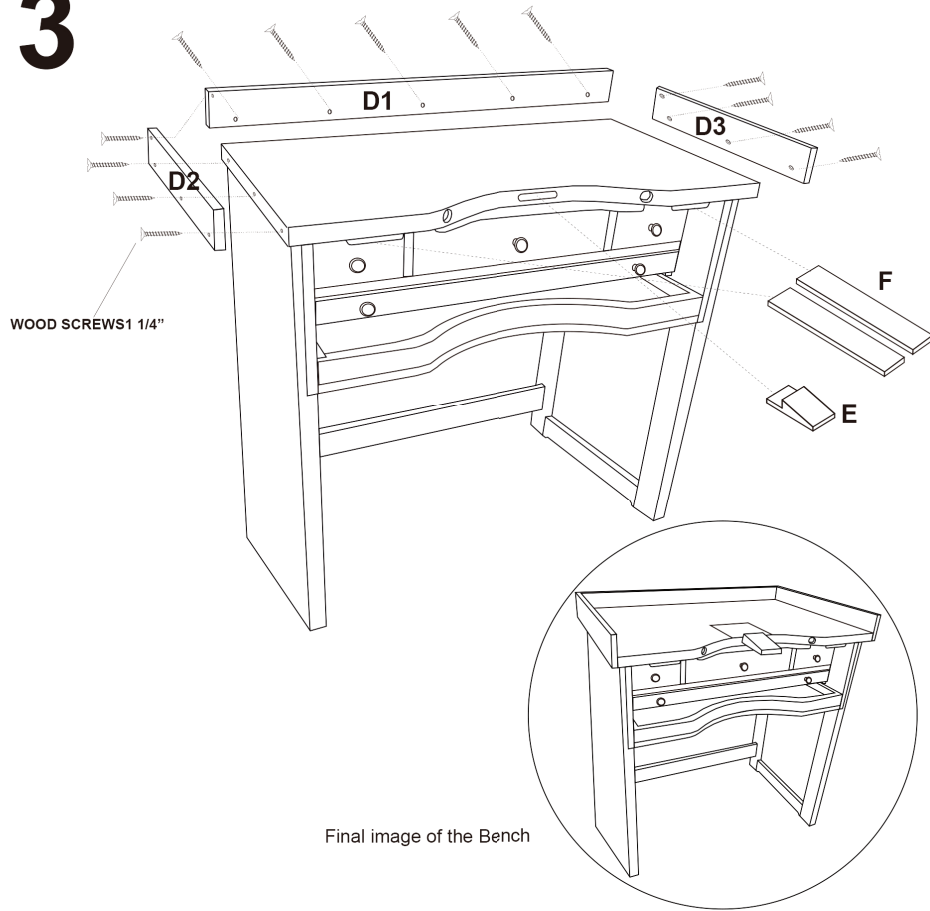

PARTS IDENTIFICATION

(A) RIGHT SIDE - 1



(B) LEFT SIDE - 1

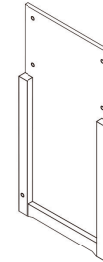

(C) LOWER CROSSBAR - 1

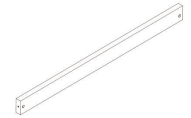

(D) BENCH BODY - 1

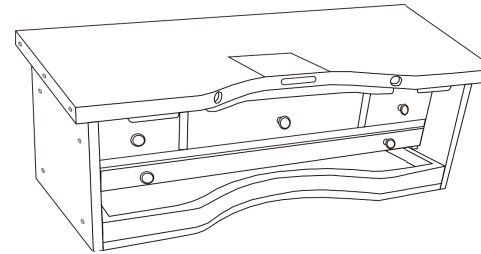

(D1 D2 D3) BENCH TOP SIDES - 3

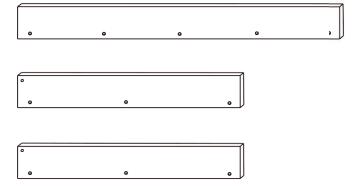

(E) BENCH PIN - 1



(F) ARM RESTS - 2

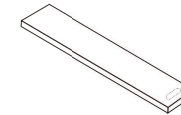

PARTS IDENTIFICATION

D1 D2 D3 Bench Top Sides - (2)
 E Bench Pin - (1)
 F Arm Rests - (2)

STAGE 3 - Bench Sides Assembling

1. Attach bench sides (D1, D2, D3) to the disk top using 13 pcs of 1 1/4" wood screws.
2. Insert Bench pin (E) and two arm rests (F).

Assembly Tools Required

1. Allen Wrench (included)
2. Screwdriver Phillips.

HARDWARE

2 1/2" BOLT, WASHER & INSERT CAMS - 2 PCS.
 1 1/2" BOLT, WASHER - 8 PCS.
 1 1/4" WOOD SCREWS - 13 PCS.
 ALLEN WRENCH - 2 PCS.

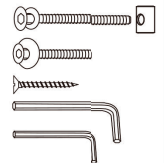

1

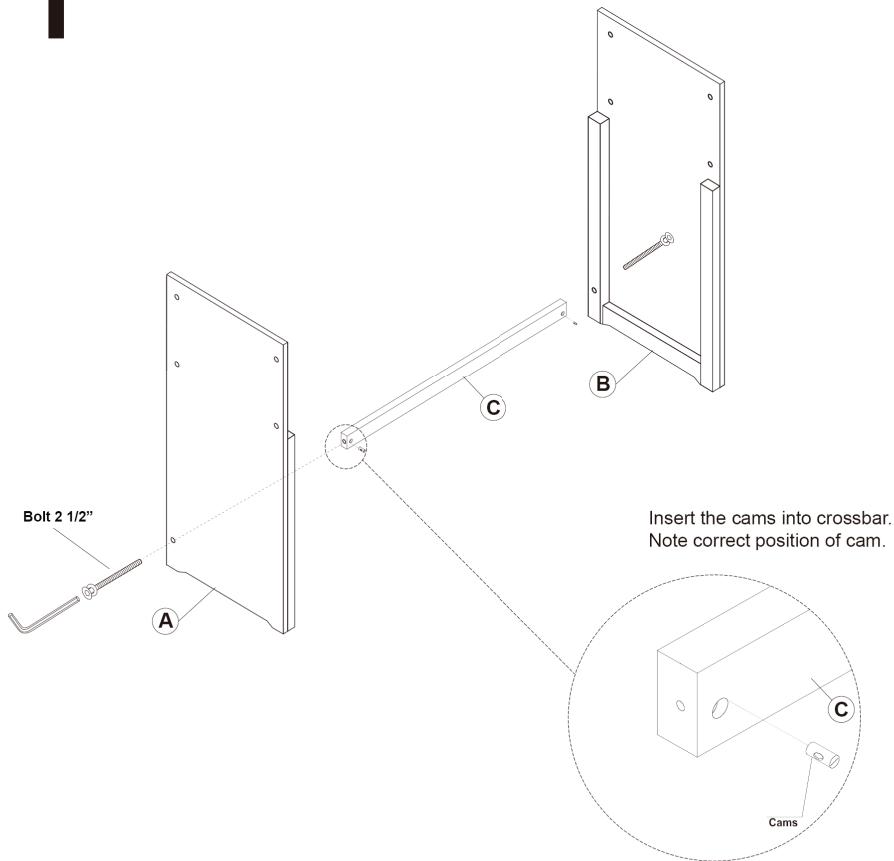

PARTS IDENTIFICATION

- A Left Side - (1)
- B Right Side - (1)
- C Lower Crossbar - (1)

STAGE 1 - Bench Frame Assembling

Attach lower cross bar (C) to sides A and B.

1. Insert two cams into crossbar. Note correct position of came as shown in illustration.
2. Fasten both sides to lower cross bar using 2 1/2" bolts. Bolts screw into cams. If alignment is not correct, adjust using screwdriver to rotate the cam. Do not fully tighten.

2

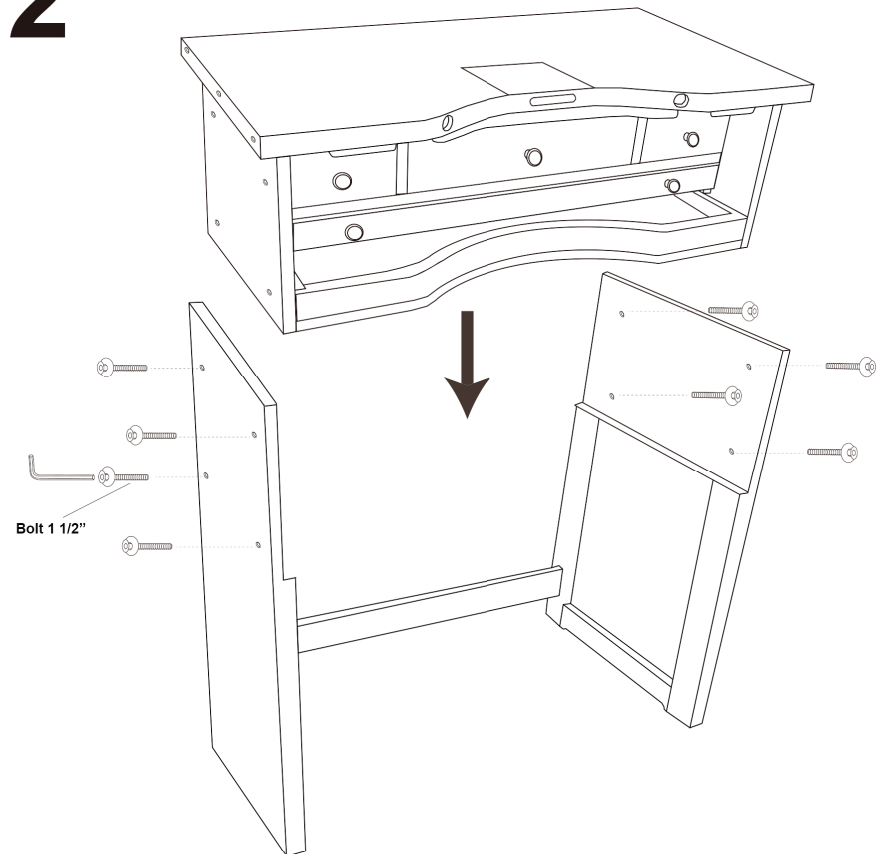

Final image of the Bench Body with the Bench Frame.

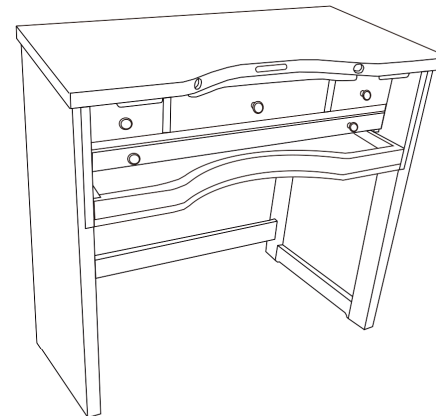

STAGE 2 - Attaching Bench Body to Bench Frame.

1. Fit bench body onto bench frame as shown.
2. Secure with eight 1 1/2" bolts with an allen key.